

INTRODUCTION

The general intent of the highway engineer is to design a roadway in which the geometry creates a safe driving environment that does not require guiderail or median barriers. Unfortunately, certain limitations are placed on this objective, even in new construction. Site conditions, economics and other considerations may make the use of guiderails the best answer to the safety problem.

DESIGN PURPOSE

The purpose of guiderails and median barriers is to make highways safer by reducing accident severity. To accomplish this objective, systems are designed to:

- 1) Reduce errant vehicle penetration.
- 2) Redirect errant vehicles in a direction parallel to traffic flow.
- 3) Minimize the hazard to the vehicle occupants during collision.

In addition to the basic objective, guiderail and median barrier systems should have certain desirable performance characteristics. These can be summarized as follows:

- 1) Minimize vehicle damage so that the automobile can be maneuvered after collision.
- 2) Be resistive to collision damage.
- 3) Be economical in construction, installation and maintenance.
- 4) Have a pleasing, functional appearance.

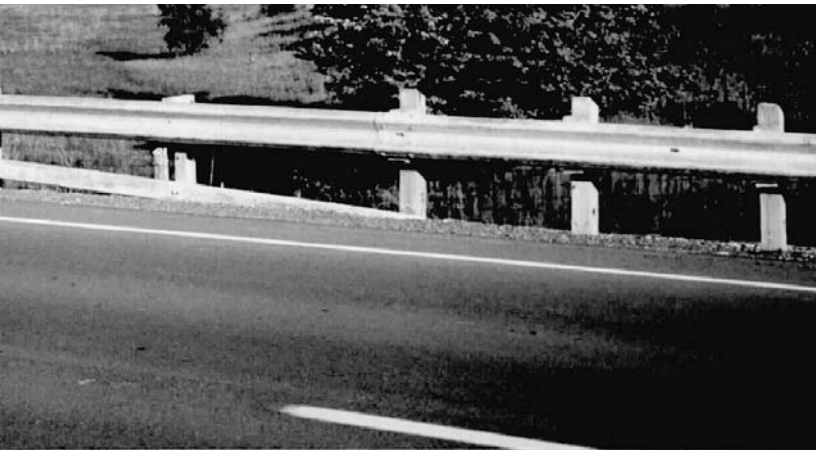

Transition of rub-rail channel with W-beam guiderail system.

Table 12.1

Barrier warrants for nontraversable terrain and roadside obstacles*,†

Bridge piers, abutments, and railing ends	Shielding generally required
Boulders	A judgement decision based on nature of fixed object and likelihood of impact
Culverts, pipes, headwalls	A judgement decision based on size, shape, and location of obstacle
Cut slopes (smooth)	Shielding not generally required
Cut slopes (rough)	A judgement decision based on likelihood of impact
Ditches (parallel)	Varies with slope
Ditches (transverse)	Shielding generally required if likelihood of head-on impact is high
Embankment	A judgement decision based on fill height and slope
Retaining walls	A judgement decision based on relative smoothness of wall and anticipated maximum angle of impact
Sign and luminaire supports ^{‡‡}	Shielding generally required for nonbreakaway supports
Traffic signal supports §	Isolated traffic signals within clear zone on high-speed rural facilities may warrant shielding
Trees	A judgement decision based on site-specific circumstances
Utility poles	Shielding may be warranted on a case-by-case basis
Permanent bodies of water	A judgement decision based on location and depth of water and likelihood of encroachment

* Shielding nontraversable terrain or a roadside obstacle is usually warranted only when it is within the clear zone and cannot practically or economically be removed, relocated, or made breakaway and it is determined that the barrier provides a safety improvement over the unshielded condition.

† Marginal situations, with respect to placement or omission of a barrier, will usually be decided by accident experience, either at the site or at a comparable site.

‡‡ Where feasible, all sign and luminaire supports should be breakaway design regardless of their distance from the roadway if there is reasonable likelihood of their being hit by an errant motorist.

§ In practice, relatively few traffic signal supports, including flashing light signals and gates used at railroad crossings are shielded. If shielding is deemed necessary, however, crash cushions are sometimes used in lieu of a longitudinal barrier installation.

Source: Adapted from *Roadside Design Guide*, AASHTO, Washington, D.C., 1996.

RESEARCH AND TECHNOLOGY

A number of provinces and states in North America, as well as other agencies (domestic and foreign) have tested guiderail and bridge rail systems. These include components of steel, wood, concrete and aluminum. Pioneer work was done by General Motors Proving Ground, with subsequent research by the state highway departments of California and New York, Texas Transportation Institute, the Cornell Aeronautical Laboratory (now Calspan) and the Southwest Research Institute.

From this continuing research and development of improved components have evolved three basic systems characterized by their deflection response. These are:

1. *Rigid*. These barriers do not deflect during collision. They function best at shallow impact angles. All collision energy must be dissipated by the vehicle itself.
2. *Semi-rigid*. The semirigid systems can yield slightly during vehicle collision, thereby reducing the magnitude of force transmitted to the vehicle. Three examples are (a) the blocked-out W-beam rail (with or without a rubbing rail), (b) the strong-beam, weak post system and (c) Thrie beam on strong post. The W-beam or Thrie beam rail spans relatively rigid closely-spaced posts. The

strong-beam (box beam) weak post system depends on the bending resistance of the strong, heavy beam element alone.

3. *Flexible.* These systems may be composed of W-beam or Thrie beam rails or of cables mounted on weak posts. These flexible systems absorb the impact energy, redirect the vehicle in the direction of traffic, and are kindest to the vehicle and driver.

In selecting a system, deflection characteristics must be considered in relation to available space. A computer program, Analysis of Roadside Design (NARD), is available for predicting deflection for W-beam and thrie-beam systems with different post spacings and single or double rails.

The “clear roadside zone” concept presented in the AASHTO Roadside Design Guide is key to determination of guiderail placement. Under this concept, a traversable, unobstructed roadside zone should extend beyond the edge of the driving lane for an appropriate distance so that the motorist can generally stop or slow the vehicle and return to the roadway safely. The width of the zone depends upon the traffic volume, the design speed, and the roadside slope. It may also be modified to reflect accident history or special site conditions. Recommendations for when barriers are warranted are provided in Table 12.1.

Tables 12.2 and 12.3 give various properties for different barrier systems. Standard barrier types are illustrated in Figure 12.1.

Table 12.2 Typical sectional properties of W-Beam guiderail per unit section*

Galvanized Thickness, mm	Area of Cross Section, mm ²	Moment of Inertia		Section Modulus		Approx. Weight	
		Horizontal, mm ⁴	Vertical, mm ⁴	Horizontal, mm ³	Vertical, mm ³	per m	per section
						kg	
2.8	1284	0.96 x 10 ⁶	12.5 x 10 ⁶	2.25 x 10 ⁴	8.03 x 10 ⁴	11.9	45.4
3.5	1652	1.24 x 10 ⁶	16.1 x 10 ⁶	2.88 x 10 ⁴	10.30 x 10 ⁴	15.1	57.6

*Bolt holes not considered. Dimensions are nominal, subject to manufacturing tolerances.

Table 12.3 Thrie Beam sectional properties

Uncoated Thickness, mm	Area, mm ²	Moment of Inertia, mm ⁴ x 10 ⁶	Section Modulus, mm ³ x 10 ⁴	Approx. Weight, kg	
				3.81 meter length	7.62 meter length
2.66	2026	1.49	3.52	69	132
3.42	2605	1.99	4.70	87	169

Ground Mounted

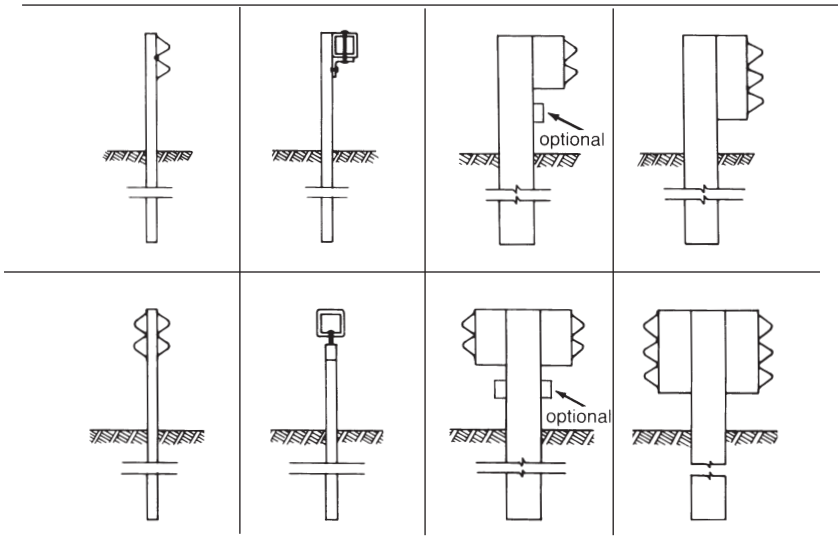

Figure 12.1 Standard barrier types.

DESCRIPTION OF SEMI-RIGID GUIDERAIL SYSTEMS

W-Beam (Figure 12.2) or Thrie Beam (Figure 12.3)

- 1) *Rail* - Rail elements are cold-formed standard W Sections of 2.8 mm (uncoated) specified thickness steel and conforming to the requirements of AASHTO Designation M 180. Standard laying lengths are 3.81 m.
- 2) *Posts* - Wooden posts, including blocks, are construction grade Southern Pine or Douglas Fir, pressure treated. Steel posts are either 110 x 150 x 4.5 mm cold formed C-sections or W150 x 13 hot rolled structural shapes conforming to A 36 / A 36 M or A 588 / A 588 M.
- 3) *Rail Coatings* (painted, galvanized, or weathering) - Standard coating is galvanized before or after fabrication with 600 g/m² of double-exposed surface, according to ASTM A 924 or ASTM A 123 / A 123 M. A heavier coating is also available. Bolts are galvanized per ASTM A 153 / A 153 M. Special weathering steel is available in which rail elements conform to ASTM A 375 or AASHTO Designation M 180, and nuts and bolts to ASTM A 242.
- 4) *Splices* (bolts, backup plates) - All splice and post bolts are flat rounded, headed with oval shoulders to prevent turning. Bolts are 16 mm ASTM A 307, galvanized to ASTM A 153 / A 153 M.
- 5) *Terminals, Transitions* - Terminal sections are 2.8 mm (uncoated) specified thickness steel and galvanized similar to the rail. Transition connectors are 3.5 mm (uncoated) thick steel and capable of transmitting the full tensile strength of the rail.

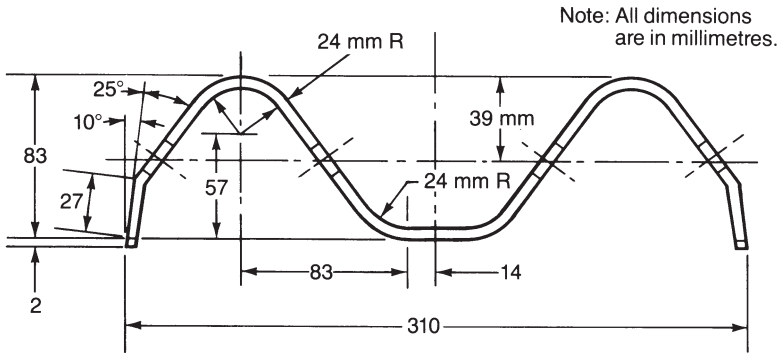
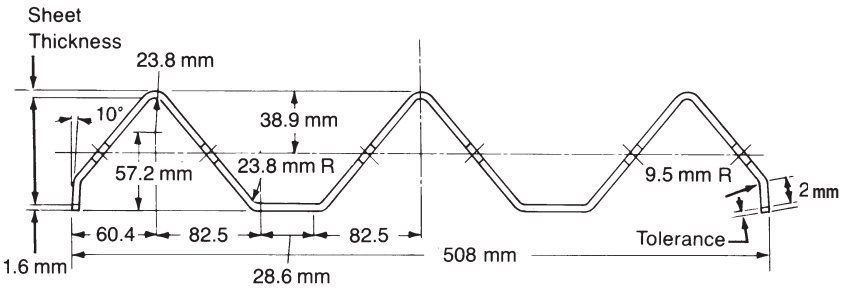

Figure 12.2 Details of a W-beam guiderail.



Note: All dimensions are in millimetres.

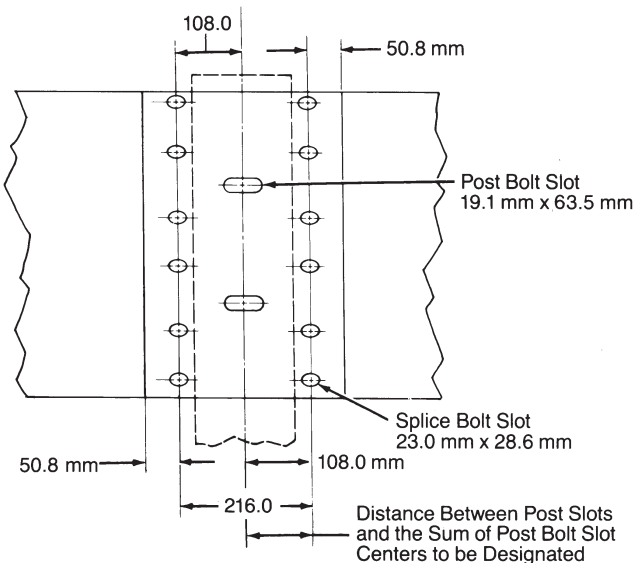
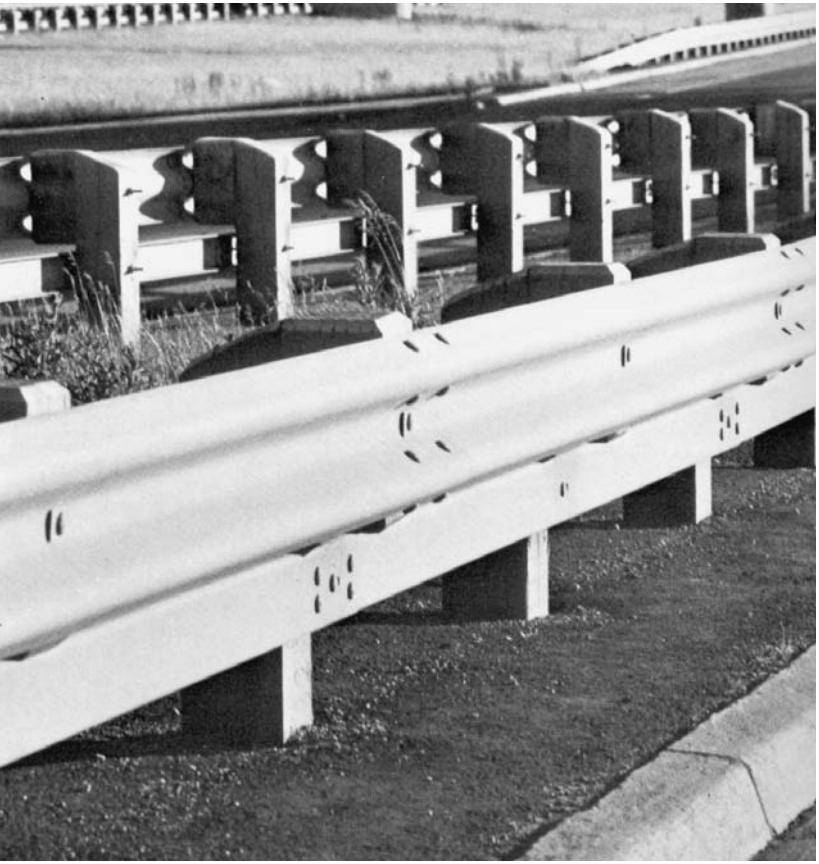

Figure 12.3 Details of a Thrie-beam guiderail.



Offset mounting of W-beam on wood post.



W-beam guiderail with channel rub rail located below.

Box Beam

- 1) *Rail* - Rail elements consist of box sections cold formed from steel tubes. The steel is ASTM A 500 or A 501; or, for weathering steel, ASTM A 618.
- 2) *Posts* - Posts are structural steel conforming to ASTM A 36 / A 36 M, or special weathering steel conforming to ASTM A 588 / A 588 M.
- 3) *Coatings* - Standard coating of entire rail system is galvanized conforming to ASTM A 123 / A 123 M. Special weathering steel conforming to ASTM A 618 is available.
- 4) *Splices* - Splice plates are of steel meeting ASTM A 36 / A 36 M. All bolts and nuts meet requirements of ASTM A 307 (except that splice bolts and nuts shall conform to ASTM A 325 / A 325 M) and be galvanized per ASTM A 153 / A 153 M.
- 5) *Curving* - Box Beam Guide Rail 150 x 150 mm - elements are shop curved for radii less than 220 m - Box Beam Median Rail 150 x 200 mm - elements are shop curved for radii less than 455 m.



Box beam median barrier across a bridge.

INSTALLATION PRACTICE

The following installation layout practices are taken from the AASHTO Roadside Design Guide.

Installation Length. Installation length includes the warranted length need and upstream and downstream terminals. Short sections should be avoided as they are often more hazardous than none. Isolated sections of unanchored guiderail should not be less than 30 m long. To eliminate short lengths, flattening of critical portions of embankment should be considered. Short gaps between installations should be avoided. Ends of guiderail should be anchored in accordance with the AASHTO Guide.

Transition Between Systems. Transition from one type to another should be smooth with a graduated stiffness. Flexible systems should not be directly connected

to rigid systems. A length of semirigid section with graduated post spacing will produce an effective stiffness transition. Recommended transitions are shown in the AASHTO Guide.

Shoulder Requirements. AASHTO recommends increasing overall shoulder width by 0.6 m on fills where guiderails are necessary. Ideally, any curb should be put in the preferred position behind the installation. If the curb must be in front of the installation, the curb should be a low mountable type.

Uniform Clearance. A desirable feature of highway design is its uniform clearance to all roadside elements. These basic elements - parapet, retaining wall, abutment, guiderail - should be in line to prevent vehicle snagging. Shoulder width should be constant whether the highway is in cut, on fill, or on structure.

General Treatment at Structures. The installation should be attached to the structure so that adequate strength of the system is developed.

Roadway narrowing transition should be gradual - 5 to 6 m longitudinally per metre of width reduction. To effect a smooth transition in rigidity, the post spacing should be graduated from the structure end, as shown in the standards.



Assembly and bolting the steel guiderail joints proceeds rapidly.

Treatment at Highway Appurtenances. Short installations around light standards, signs and gore areas are not recommended because they increase accident frequency, seldom decrease accident severity, and frequently cost more than modification or relocation of the appurtenance. Serious consideration should be given to relocating the appurtenance or utilizing breakaway construction with no barrier. For large signs, bridge abutments, large trees, and other roadside obstacles, examples are shown.



Typical bridge tubular steel railing.

INSTALLATION OF GUIDERAIL OVER LOW COVER SOIL-STEEL STRUCTURES

When soil-steel structures are installed in minimum cover conditions, there may not always be a sufficient depth of cover to accommodate the required embedment of guiderail posts. The Texas Transportation Institute researched this topic and presented their findings at the annual Transportation Research Board meetings in 1992.

The report detailed a recommended procedure to allow increased guiderail post spacing to either 3810 mm or 5715 mm centres from the typical spacing of 1905 mm. When increasing the post spacing, two sections of guiderail are nested together to provide a net coverage greater than the clear post spacing.

When spanning a 3810 post spacing, the minimum nested rail length required is 7620 mm (double length rail). The nested rail sections extend one standard post spacing (1905 mm) either side of the 3810 post spacing.

When spanning a 5715 post spacing the minimum nested rail length required is 11430 mm (triple length rail).



Transition from bridge rail to box-beam guiderail.

The nested rail sections extend one standard post spacing (1905 mm) downstream (“down-traffic direction”) and two standard post spacings (1905 mm) upstream (“up traffic direction”) from the 5715 spacing. Whenever nested rails are employed to span a post spacing greater than the standard 1905 mm, a rail joint cannot be located within the zone of the increased post spacing.

BRIDGE RAILING

Safety and minimal damage are the objectives of railings on bridges and overpasses for errant vehicles and others on the bridge, and for the traffic on the roadways, railroads, or waterways below. A bridge rail must *restrain* a colliding vehicle, *prevent* it from vaulting, and at the same time, *slow* it to a safe speed without severe redirection, pocketing, or snagging. Furthermore, the stiffer bridge rail must be coordinated with the softer off-deck guiderail system.

During past decades, progress toward more reliable bridge rail systems has resulted from the efforts of engineers involved in design and full-scale research. The trend is towards integrating roadway and bridge rails into one cohesive system.

BIBLIOGRAPHY

AASHTO, *Roadside Design Guide*, American Association of State Highway and Transportation Officials, 444 N. Capitol St. N.W., Ste 249, Washington, D.C. 20001, 1996.

AASHTO, *Highway Safety Design and Operations Guide*, American Association of State Highway and Transportation Officials, 444 N. Capitol St. N.W., Ste 249, Washington, D.C. 20001, 1997.

AASHTO, *A Guide to Standardized Highway Barrier Hardware*, American Association of State Highway and Transportation Officials, 444 N. Capitol St. N.W., Ste 249, Washington, D.C. 20001, 1995.